

WEIGHT CLASS

9.8 TONNE MONO

10.1 TONNE 2-PIECE

| TB295W |

WHEELED EXCAVATOR

TAKEUCHI
Japanese for Reliability

TB295W redefining wheeled excavator performance

The TB295W is Takeuchi's new high performance wheeled excavator, packed full of on-road features. A powerful 4 dual-wheel drive machine, the new TB295W is designed and built for motorway, road and street works applications with out-rigger options for added stability.

A very flexible on-road vehicle built for maximum excavator performance; it comes complete with a new 85kW Deutz engine, final Tier 4 offering power performance combined with maximum breakout force.

The TB295W is available as a mono or 2- piece boom. The mono weighs in at 9856kg (10,126kg when complete with outriggers) and the 2-piece boom 10,132 (10,267kg). With a massive dig depth of 3895mm (4115mm) and ground reach to 6570mm (7505mm) the TB295W provides heavy duty on-site performance.

The latest upgrade to the TB295W includes new improved all round LED lighting right around the cab, a new colour LCD panel for enhanced operator controls and final Tier 4 emission Deutz engine.



HEAVY DUTY BUILD - POWERFUL

Powered by a very fuel efficient final Tier 4 emission Deutz Engine, combined with AdBlue, providing controlled emissions for low emission construction zones and cities.

The turbocharged diesel engine with auto idle and a dial throttle control for added fuel saving economy.

The heavy-duty boom and dipper arms are robust for tough breaking out. With a 2-piece option providing added versatility on site.

Takeuchi's TB295W is a proven powerful wheeled 9.5 tonne excavator ideal for streetworks / on-road excavating.

For plant hire and contractors a wheeled option is essential for road applications and the new TB295W offers a powerful addition to the fleet.

For larger applications a powerful breakout performance is essential and the TB295W offers a massive breakout force and operating capacity.

Whatever the application - roadworks, demolition, groundworks or streetworks the TB295 gives a reliable wheeled performance.

With a reputation for reliability, Japanese build quality makes all the difference.



OPERATOR COMFORT

The cab is isolated and provides a cushioned performance whilst driving and excavating.

A large enclosed ROPS/FOPS cab with digital air-con climate control as standard, with defrost, wiper and rainguard. AM/FM radio and MP3 socket, retractable front window, large skylight with sun shade, removable lower window section, and 24v power outlet. A 10-way adjustable heated air suspension seat.

NEW LED LIGHTING

Improved visibility in the dullest winter conditions with powerful new all round LED lighting, assists not just the operator but other on-site vehicles.



MAXIMUM OPERATING PERFORMANCE

With a machine footprint of just 2335 x 3745mm, the new TB295W has a relatively compact size to get maximum accessibility on restricted streetwork sites.

Takeuchi joystick controls give finger-tip precision control with smooth hydraulics. Fitted with a cushioned main boom, arm and swing cylinders. Both the boom and dipper arm have a hose-burst check valve, to help minimise cylinder drift and maintain load control in the event of a hose failure.

The selectable lift alarm provides an audible warning when the boom is reaching maximum hydraulic lifting capacity. The 2-piece boom option provides added operator versatility.



MAINTENANCE FEATURES

Ground level easy access points for the battery and regular service points. The machine comes with a large well positioned tool box under the cab, supplied with a tool kit and grease gun.

Auto refuel pump & fuel drain for easy fuelling and fuel cleaning when necessary

- Electronic engine monitoring system
- Self bleeding fuel system with high capacity fuel filters

Reliable well protected hydraulic hoses help reduce maintenance costs.



ON - SITE FEATURES

Rear fisheye mirror, cab and boom work lights provide added on-site safety.

A larger than average parallel lift dozer blade as standard provides for effective grading and ground clearance. A reversing camera with in-cab split screen display adds to on-site safety.

INDEPENDENT OUT RIGGERS are a factory fitted option. Easy to position to provide the added stability that might be required on gradients and un-even terrain.





ROAD FEATURES

TB295W is a road legal vehicle when registered and taxed.

A highly flexible on-road excavator, with excellent travel speed up to 30kph. Rugged axles and undercarriage provides heavy duty strength in all terrains.



AXLE & UNDERCARRIAGE

The undercarriage and axles are built for the rigours of road and site with rigid strength to withstand heavy duty impacts. The undercarriage has universal out rigger and blade mounting points at both ends of the machine.



SAFETY

Hi visibility well positioned road and LED work lights alongside reversing mirrors make for the safest possible drive. The added height of TB295W gives excellent all-round operator visibility on-road and on-site with in-built reversing camera as standard.



BRAKES

Highly efficient oil immersed hydraulic brakes. Selectable switch from manual to auto axle lock when digging.



DRIVING

The TB295W is an easy to drive wheeled option with all the typical-on-road features, an adjustable steering column both height and rake, provides for all sizes of operators to give a comfortable drive.

Selectable hand or foot controls for operator performance.



TRAVEL SPEED

With up to 30kph travel speed and auto cruise facility, the TB295W is ideal for on-road highways and street works applications.

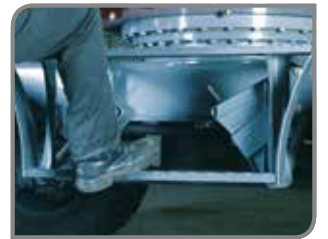

NEW LCD FULL COLOUR DISPLAY

Provides easy to see functionality. The colour VDU gives excellent operator control illuminating all machine functions and warning alerts. Includes a split screen VDU with both operating functions and reversing camera.

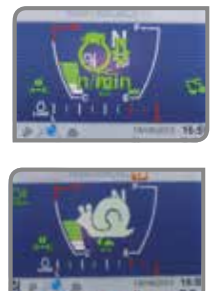

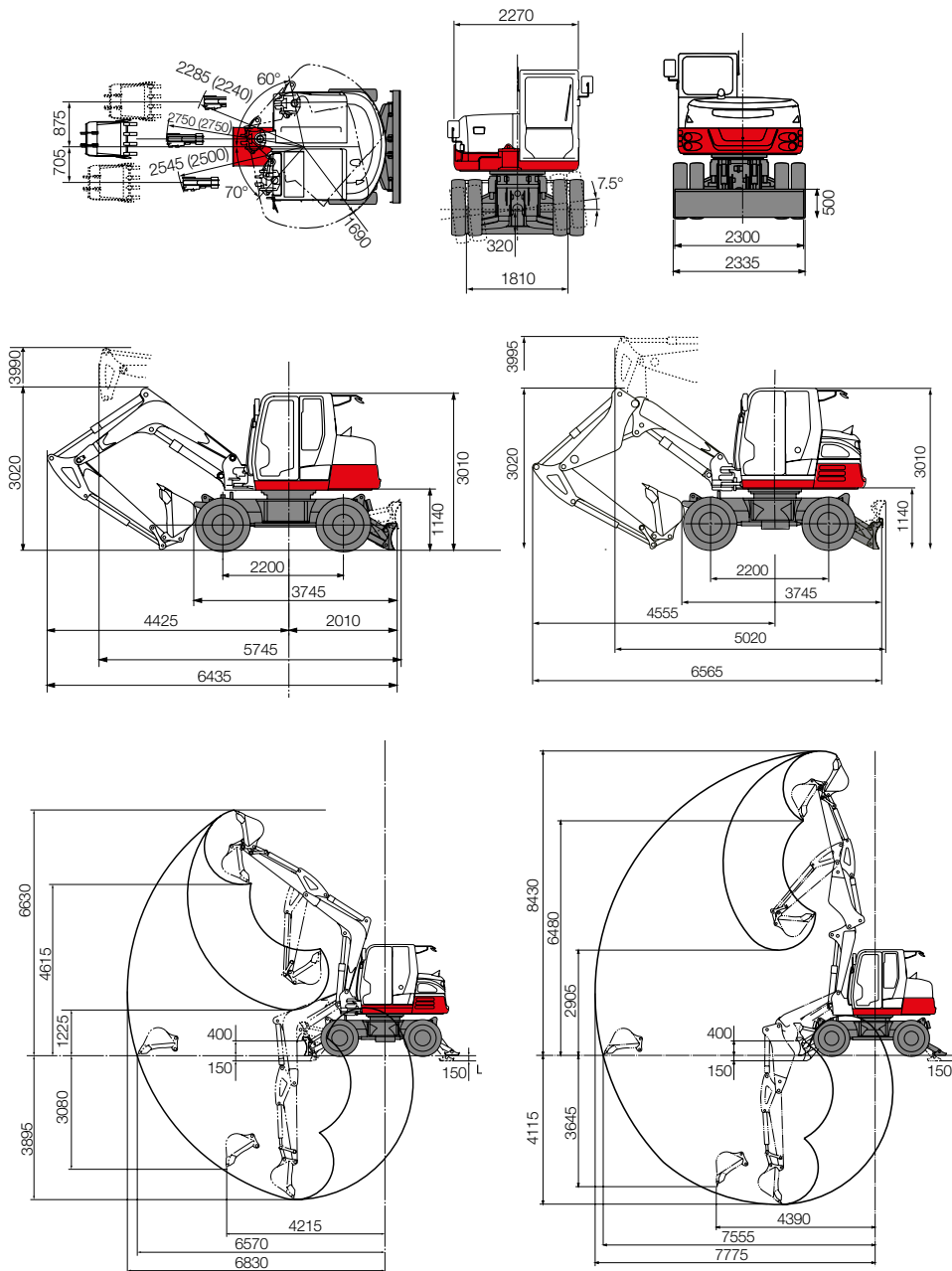

For more information locally

call us direct, or contact:

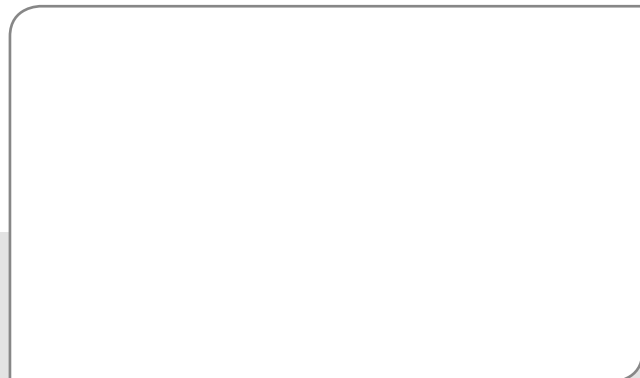

Takeuchi Mfg (UK) Ltd, Unit E2B Kingsway Business Park,
John Boyd Dunlop Drive, Rochdale, Lancashire OL16 4NG
Tel: 01706 657 722 Fax: 01706 657 744

Southern Depot at 20 Colthrop Business Park
Colthrop Lane, Thatcham, Newbury, Berks RG19 4NB
Tel: 01635 877 196 Fax: 01635 877 195

www.takeuchi-mfg.co.uk Email: sales@takeuchi-mfg.co.uk

TB295W

Standard UK Specification - Long Dipper - Mono Boom
(Twin Boom option available)

Engine	
Make	DEUTZ
Model	TCD3 6L4
Rated Output (kW)/rpm/HP	85/2200/113.9
Cylinders	4
Displacement (cc)	3621
Electrical System	24 V 90 A x2
Dimensions & Weight	
Operating Weight Mono Boom (bucket, hitch, fuel, blade/with outrigger)	9856 / 10126kg
Operating Weight 2 Piece Boom (bucket, hitch, fuel, blade/with outrigger)	10132 / 10267kg
Overall Length (mm)	6435 (6565)
Overall Length on road (mm)	5745 (5020)
Width (mm)	2335
Height (mm)	3010
Ground Clearance (mm)	320
Min. radius of machine & attach	2750 (2705)
Slew Radius (mm)	1690
Dozer Blade (W x H) (mm)	2300 x 500
Operating Information	
Max Digging Depth (mm)	3895 (4115)
Max Dump Height (mm)	4615 (6480)
Max Reach at Ground Level (mm)	6570 (7555)
Max Vertical Digging Depth (mm)	3080 (3645)
Bucket Digging Force (kN)	58.9
Long Arm Digging Force (kN)	39.7
Hydraulic System	
Set Pressure (bar)	275
Pump Type	Variable piston x 2, double gear x 1
Hydraulic Flow (l/min)	176+156+59.6+43.1 +40.3+35.6+15.4
Auxiliary Flow / Hi Flow (l/min)	70 / 120
Swing System	
Boom Swing Angle (R/L)	60°/70°
Slew Speed (rpm)	10.1
Slew Motor	Constant Vol Piston
Slew Brake	Disc
Undercarriage	
Tyre Size	8.25 - 20 - 14PR
Drive Line	All Wheel Drive
Travel Brake	Disc & Brake Lock
Steering	Front Setting System
Wheelbase	2200
Tyre Pressure (psi)	95
Travel Speed (K/ph)	35
Maximum Gradeability	35°
Capacities	
Hydraulic System (l)	200
Fuel Tank (l)	162
AdBLUE (l)	10
Engine Lubrication (l)	10

All dimensions unless otherwise stated are in millimetres.

6/2018

*Lifting; the mass weight of slings / hitches / bucket to be deducted from the rated load to determine the net load that may be lifted.

Takeuchi machines come with a 2 year/2000 hours warranty as standard. Warranty exceptions to 1 year; fuel injection systems, electrical components, paint work.

In accordance with our established policy of constant improvement, we reserve the right to amend these specifications at any time without notice. Photographs shown may feature non-standard equipment.